

Introduction for plastic outdoor electric box:

- 1 Use of one sachet of silica gel for water-proof which is highly water-proof and highly sealed
- 2 Use of copper bolts and stainless steel screws for the external body
- 3 Wall Hanging nails and wall hanging screws
- 4 Screws spots with their covers
- 5 Water-proof level up to IP68
- 6 Exclusive package for each unit

We are pleased to provide you with:

- 1 Drilling,Punching ,etc. Welcome to provide drawings custom.
- 2 Silkscreen ,Laser Carve, Sticker ,etc.
- 3 Short lead time,normally 3-5 days after payment(according to quantity)
- 4 Prompt response for your inquiry

Applications:

It is widely used in electronic, instrumentation, automation, communications, power supply units, student projects, amplifiers, Medical and wellness devices, test and measurement equipment, industrial control, peripheral devices and interfaces, switch boxes.

Warm Prompt:

Welcome to contact us for more details and quotations for electrical box ,your inquiry will surely get prompt response in 24 hours!

Detail Pictures:

SZOMK

*Customizable
Cutout, sticker
Silkscreen, color*



Model No. **168*120*56 mm** **222g**
BWP10011-A2 **6.61*4.72*2.2 inch**

SZOMK

*Customizable
Cutout, sticker
Silkscreen, color*



Model No. **168*120*56 mm** **222g**
BWP10011-A2 **6.61*4.72*2.2 inch**

SZOMK

*Customizable
Cutout, sticker
Silkscreen, color*

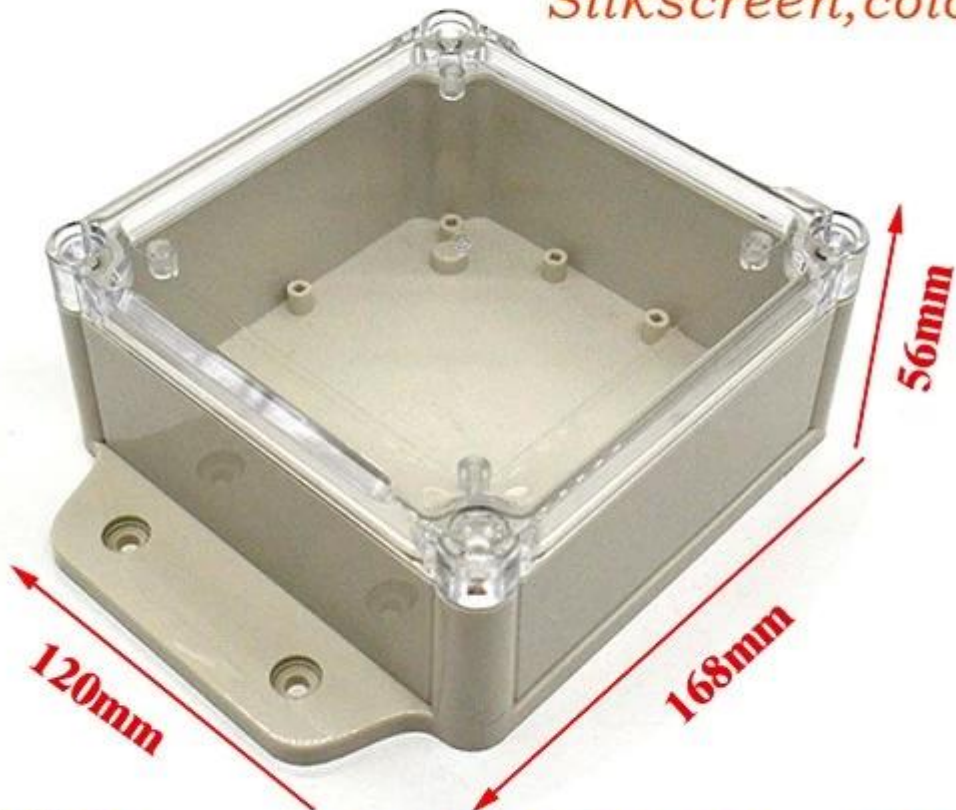

Model No. 168*120*56 mm 222g
BWP10011-A2 6.61*4.72*2.2 inch

SZOMK

*Customizable
Cutout, sticker
Silkscreen, color*



Model No. 168*120*56 mm 222g
BWP10011-A2 6.61*4.72*2.2 inch

SZOMK

*Customizable
Cutout, sticker
Silkscreen, color*



Model No. 168*120*56 mm 222g
BWP10011-A2 6.61*4.72*2.2 inch

SZOMK

*Customizable
Cutout, sticker
Silkscreen, color*

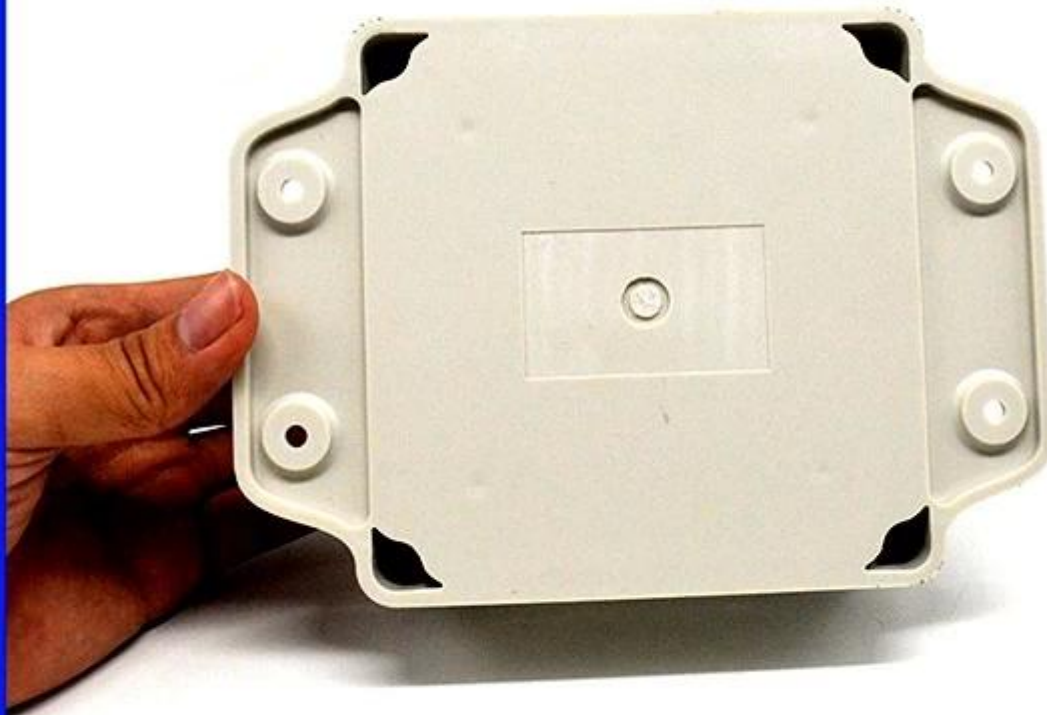

Model No. 168*120*56 mm 222g
BWP10011-A2 6.61*4.72*2.2 inch

Drawing:

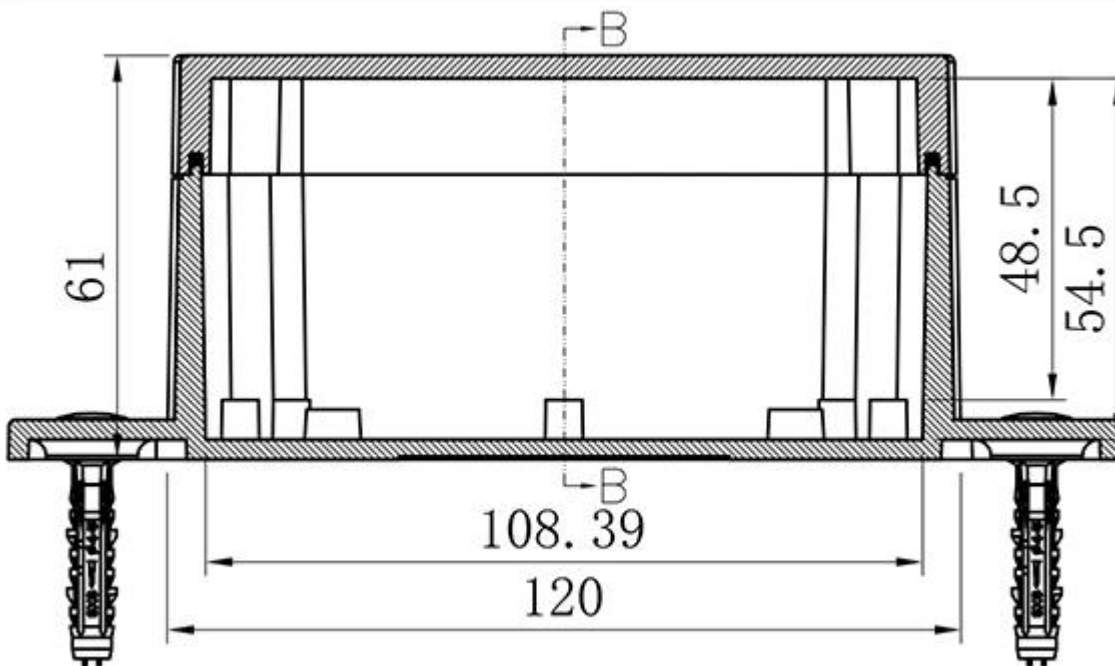
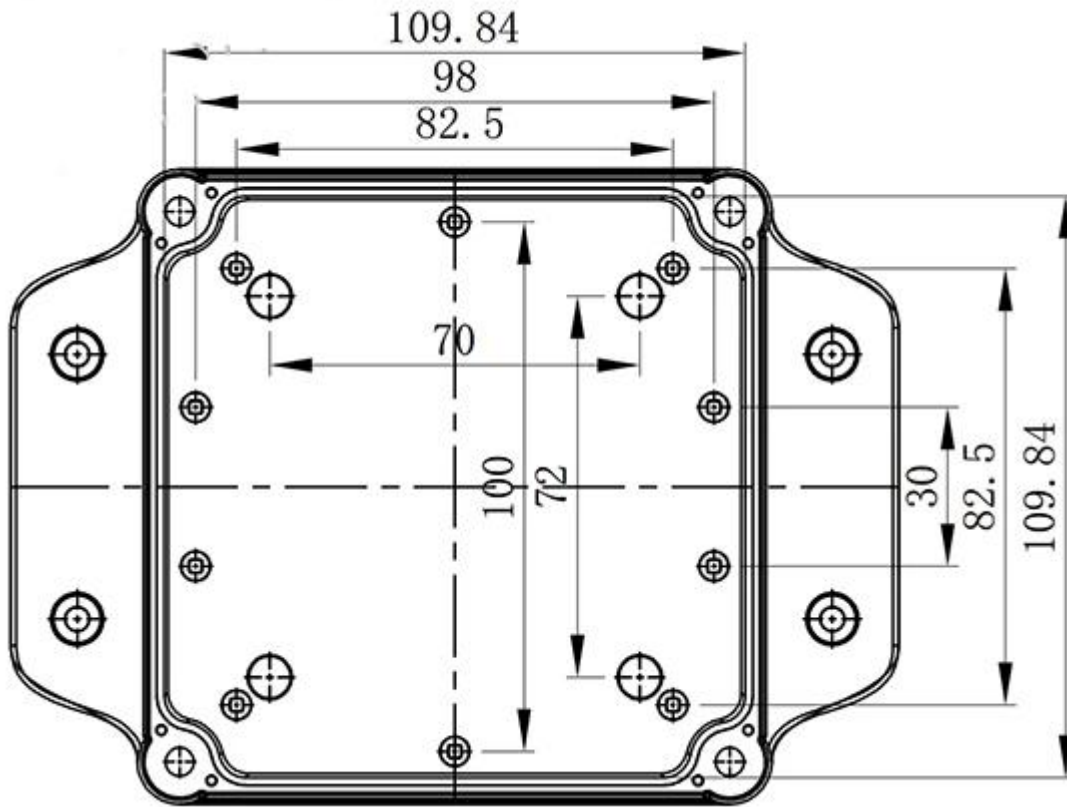

Custom process:

1. Cutout
2. Silkscreen and Engraving
3. Sticker and Paster



Company Shots and Contact information:



Packaging & Shipping



Company Information



Shenzhen Futian Huaqiang Electronic World OMK Electronic Sales Departmen

This complex, during long years of efforts with it's own experienced group and sole facilities for improvement of productions and promotion of products quality, is now one of the largest suppliers of all kinds of metallic and plastic enclosures in different fields of electronic, electrical, communication, medical, industrial and research prtojects purposes.

In today's industrial world and with the rapid development of all industries, the need of these products is sensed more than ever. Therefore by offering the best quality and service, we try to meet these needs and help you to reach your ideals.

Factory and showroom





QQ

2110283100



Tel

86-755-83222882
86-130-266-19680



Add

628Room,505 Building ,Shangbu industry,
Hangtian road ,Futian district ,Shenzhen,
China,518031



Email

harriet@szomk.com.cn



skype

szomk-002

24 Hours
Response
in
hours

For more infor. products please visit www.szomk.com.cn
Thanks for your time !