

مواصفات:

مكان المنشأ: شننتشن ، الصين

نوع: بلاستيك إلكترونيات الضميمة مربع تقاطع

نموذج رقم: AK-H-60

الحجم: 180 * 81 * 45 mm

المادة: البلاستيك ABS

عينة موك: 1 قطعة

حسب الطلب الخدمات: انقطاع ، بالشاشة الحريرية ، اللون ، ملصقا ،
النقش بالليزر ،
ورقة الاكريليك ، خلق العفن

موك مخصصة: 20 جهاز كمبيوتر شخصى

التعبئة: كرتون

SZOMK



85g

AK-H-60

▶ Enclosure Manufacturer
www.chinaenclosure.com

SZOMK

Customizable
cutout, sticker
silkscreen, color



Weight: 85g

Model No. AK-H-60

Size: 180*81*45mm

7*3.2*1.7inch

SZOMK



SZOMK



SZOMK



SZOMK



SZOMK



SZOMK



表面要求：纹面

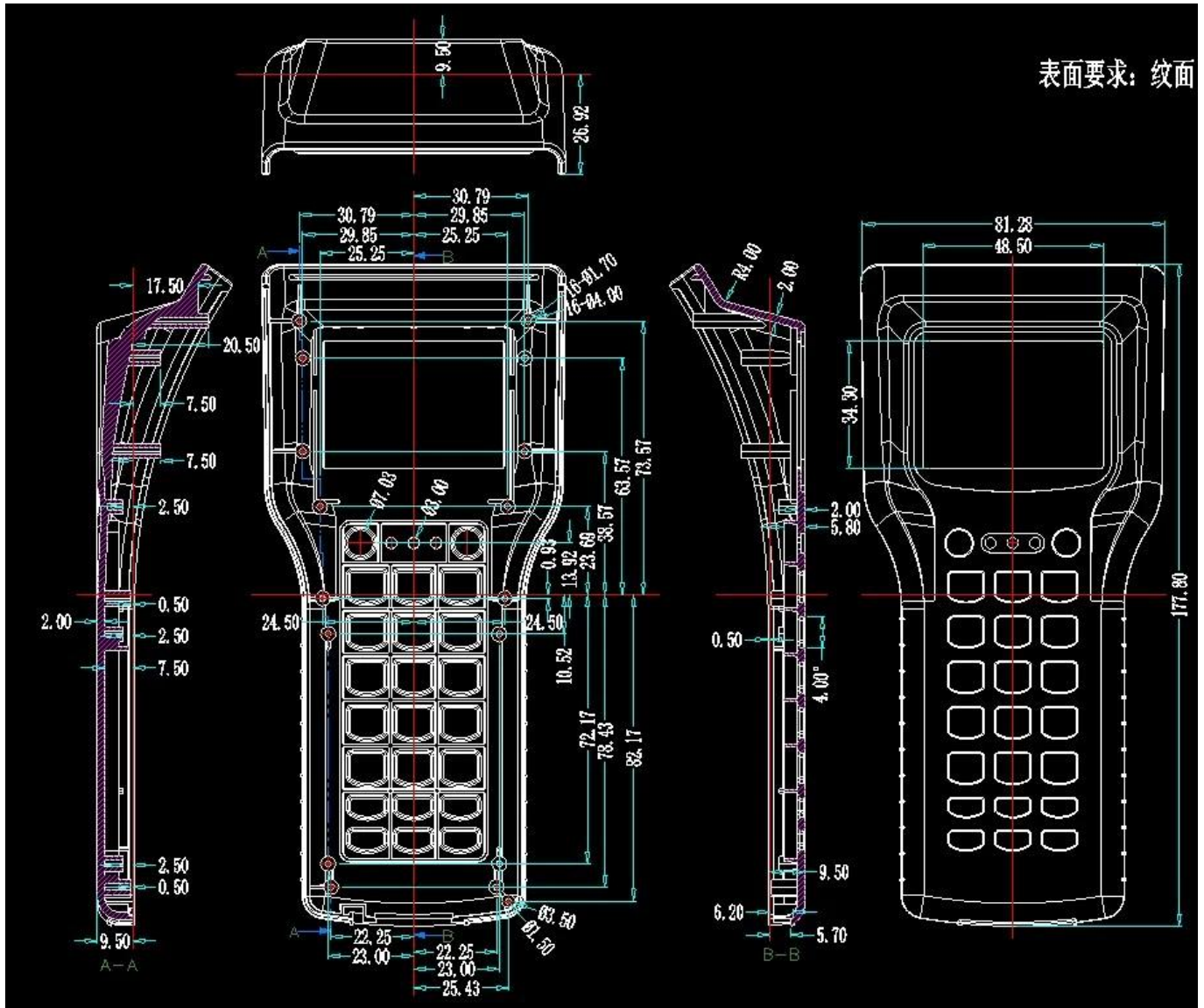

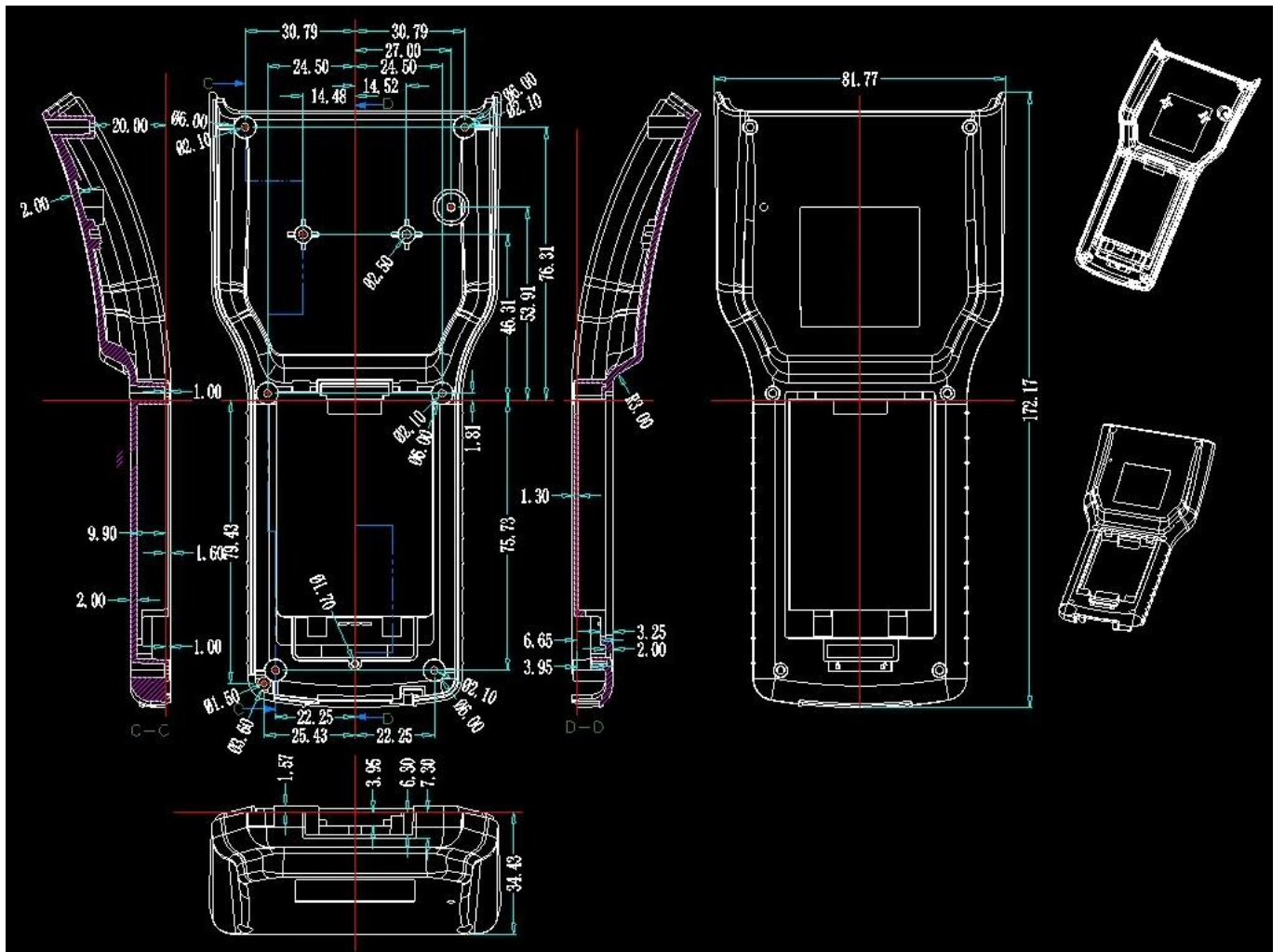

□□□□ □□□□ □□□□ □□ □□:

- 1 □ □□□□□□□ □□ □□□□□□ □ 2 □□□□□□□□□□ □□ □□□□□□
- 3 □ □□□□□□ □□□□□ □ 4 □□□□□□ □□□□□□
- 5 □ □□□□□□□ □□ □ 6 □□□□□□□ □□□□□□
- 7 □ □□□□□□□ □□□□□□ □□□□□ □□□□ □ 8 □□□□□□□ □□□□□□
- 9 □ □□□□□□□ □□□□□□ □□□□□ □ 10 □□□□□□□ □□□□□□
- 11 □ □□□□□□□ □□□□ □□□□ □ 12 □□□□□□ □□□□□□
- 13 □ □□□□□□□ □□□ □ 14 □□□□□□□□
- 15 □ □□□□□ □□□□ □ 16 □□□□□ □□□□□□□□□□ □□□ □□□□□□



Plate



Silkscreen



Sticker

*We can do
customize*

Cutout



Silicone Seals



Color



We can do customize

Cut holes
Silkscreen
Sticker



We can do customize

change the color



We can do customize

PVC lable
Acrylic plate
Sticker



We can do customize

Cut holes
Silkscreen
Laser carve



We can do customize



**UV
Protection**



We can do customize

Cut holes
Silkscreen
Sticker



Company Information



Shenzhen Futian Huaqiang Electronic World OMK Electronic Sales Department

This complex, during long years of efforts with its own experienced group and sole facilities for improvement of productions and promotion of products quality, is now one of the largest suppliers of all kinds of metallic and plastic enclosures in different fields of electronic, electrical, communication, medical, industrial and research projects purposes.

In today's industrial world and with the rapid development of all industries, the need of these products is sensed more than ever. Therefore by offering the best quality and service, we try to meet these needs and help you to reach your ideals.

Exhibition



Certificate



Factory and showroom



Packaging & Shipping



SZOMK

Shenzhen Futian Huaqiang Electronic World OMK
Electronic Sales Department

Tel: +86-755-83222882 E-mail: hyj@szomk.com.cn



SZOMK

Our packaging

Plastic foam packaging



Metal shell packaging

Plastic box packaging



