

It is widely used in electronic, instrumentation, automation, communications, power supply units, student projects, amplifiers, Medical and wellness devices, test and measurement equipment, industrial control, peripheral devices and interfaces, switch boxes.



Vorteile der ABS-Kunststoffgehäuse Elektronik-Verteiler

1. Hat eine starke Beständigkeit gegen Abrieb, Witterung, Korrosion.
2. Kann auf der Oberfläche einer Vielzahl von Farben gebildet werden, um Ihre Anforderungen zu maximieren.
3. Haben Sie eine starke Härte, kann Ihre Elektronik gut geschützt werden.

Was wir für Sie tun können

- 1 Drilling, Punching, etc. Willkommen, um benutzerdefinierte Zeichnungen zur Verfügung zu stellen.
- 2 Pulverbeschichtung, Pinsel, Politur, Siebdruck, Laser Carve, Aufkleber, Gravur, Acrylglas.
- 3 kurze vorlaufzeit, normalerweise 3-5 tage nach zahlung (nach menge)
- 4 prompt antwort für ihre anfrage

Detaillierte bilder von abs kunststoffgehäuse elektronik verteilerkasten

SZOMK



▶ **Enclosure Manufacturer**
www.chinaenclosure.com

SZOMK

Customizable
cutout, sticker
silkscreen, color



Weight: 36g
Model No. AK-S-02

Size: 3.74*2.17*0.91 inch
95*55*23 mm

Detaillierte Zeichnungen

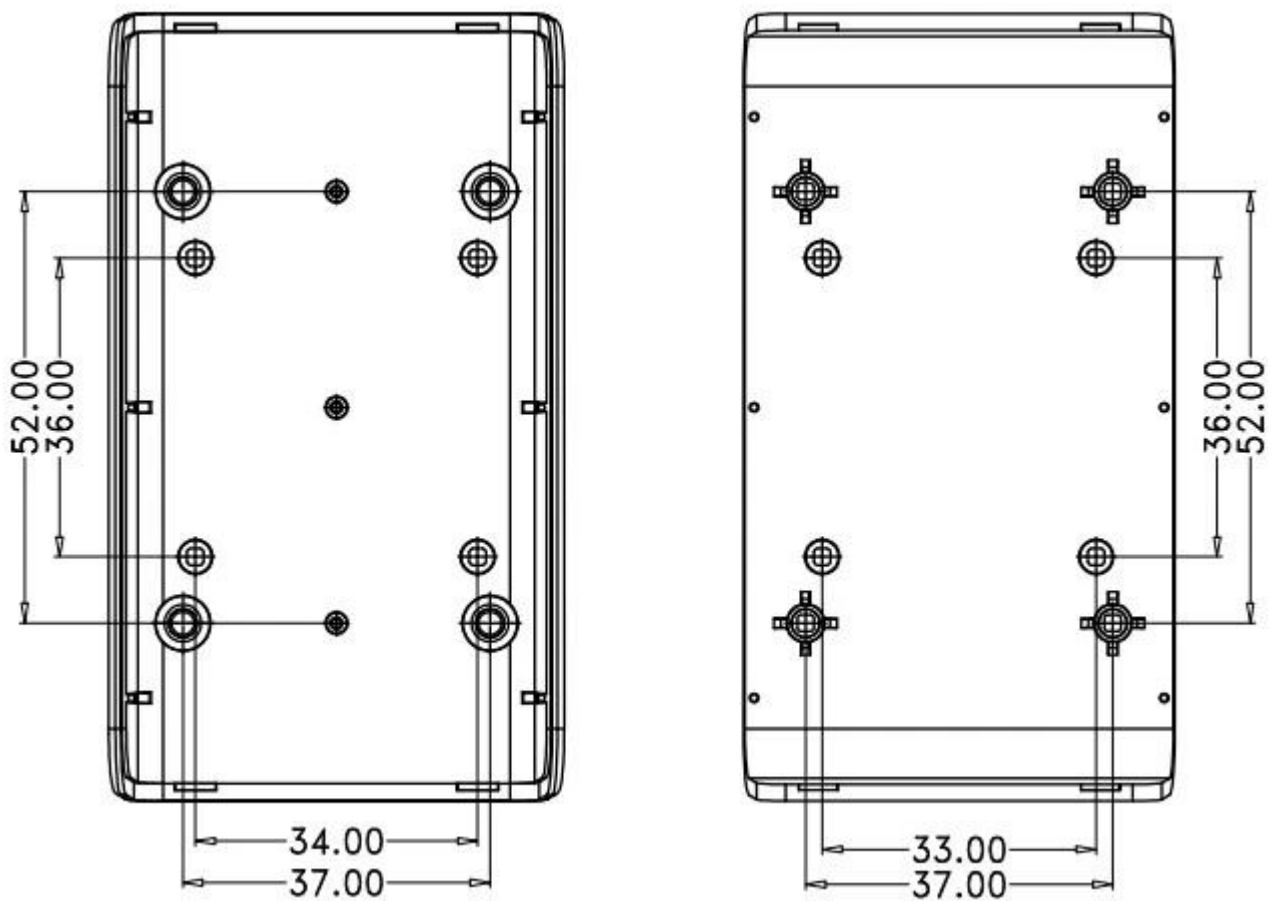
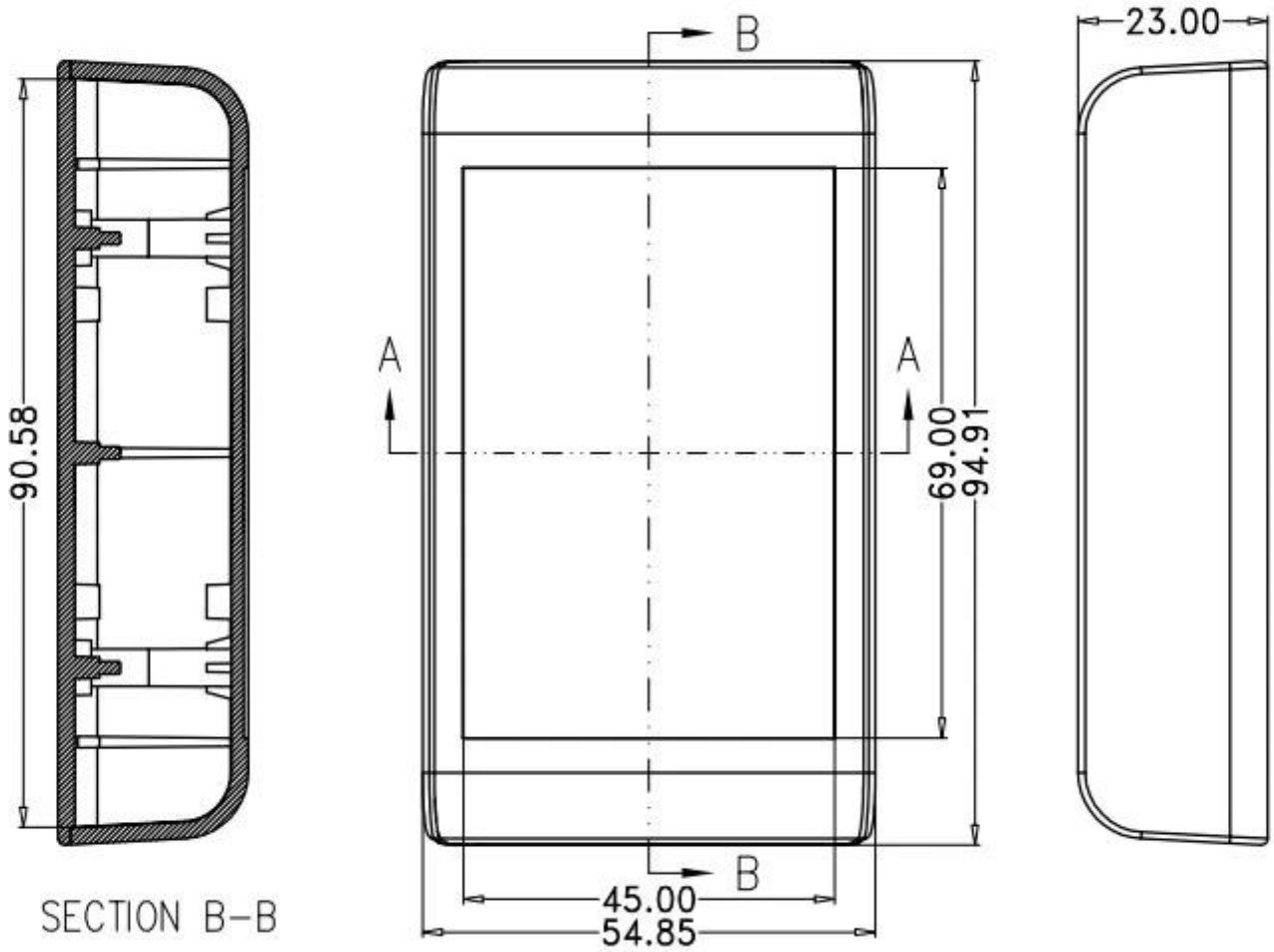

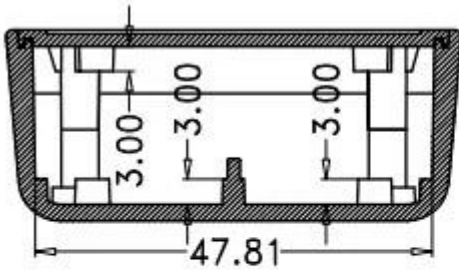

SECTION A-A

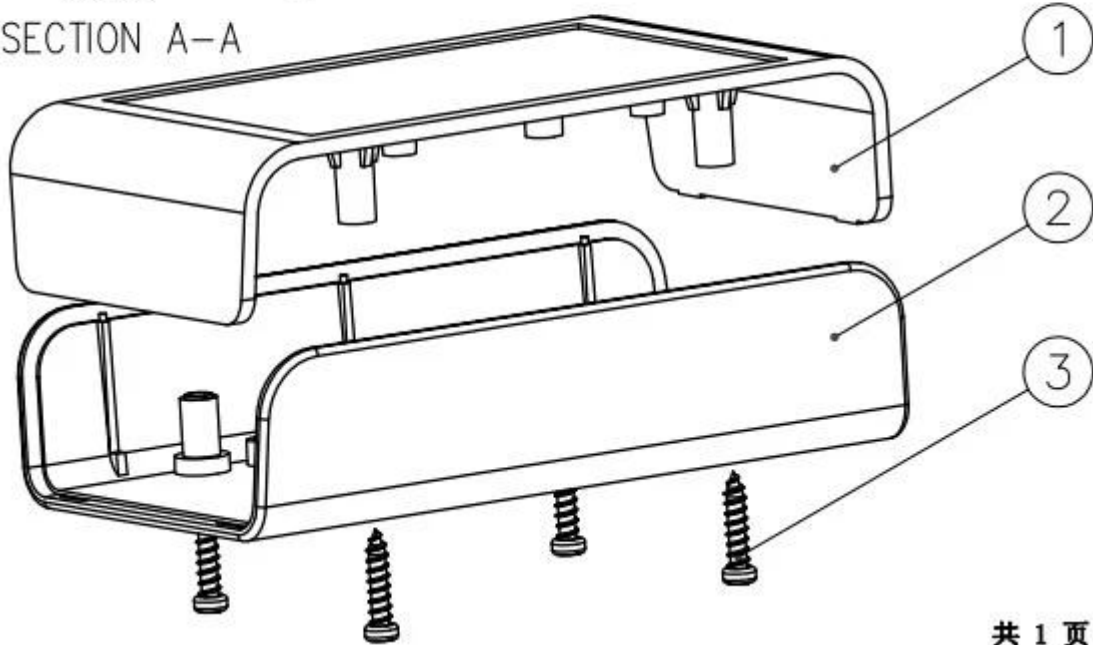

共 1 页

Andere Anpassung



SZOMAK

WE CAN DO

- Provide thousands of public enclosure**
MOQ: 1 piece
- Small order custom** MOQ: 20-30 pcs
- Design private custom enclosure (provide PCB)**
- Molding, tooling (provide sample / STEP file)**







cutout, laser engrave, screen printing, sticker, acrylic plate, pvc label, color, silica gel rings, etc.



WE CAN DO

**For HOUSING some of the Processing,
Openings, Screen, Stickers, PVC LABEL**



Verpackungs- und Versandmethoden



Our packaging

Plastic foam packaging



Metal shell packaging



Plastic box packaging



Packaging & Shipping



Kontaktiere uns



QQ

3010748891



Tel

81-755-83222882
+86 18819073301



Add

16-6Floor, 505Building ,Shangbu Industry
Area, Hangtian RD, Futian District ,Shenzhen
China



Email

smile@szomk.net



skype

szomk017