

It is widely used in electronic, instrumentation, automation, communications, power supply units, student projects, amplifiers, Medical and wellness devices, test and measurement equipment, industrial control, peripheral devices and interfaces, switch boxes.



Avantages de la boîte de distribution électronique de boîtier en plastique abs

1. A une forte résistance à l'abrasion, aux intempéries, à la corrosion.
2. Peut être formé sur la surface d'une variété de couleurs, afin de maximiser vos besoins.
3. Avoir une forte dureté, peut être bien protégé vos appareils électroniques.

Que pouvons-nous faire pour vous

- 1 Percer, poinçonner, etc. Bienvenue pour fournir des dessins personnalisés.
- 2 Revêtement en poudre, brosse, polonais, sérigraphie, découpage au laser, autocollant, gravure, feuille acrylique.
- 3 délai court, normalement 3-5 jours après le paiement (selon la quantité)
- 4 réponse rapide pour votre demande

Images détaillées de la boîte de distribution électronique de boîtier en plastique abs

SZOMK



▶ **Enclosure Manufacturer**
www.chinaenclosure.com

SZOMK

Customizable
cutout, sticker
silkscreen, color



Weight: 36g
Model No. AK-S-02

Size: 3.74*2.17*0.91 inch
95*55*23 mm

Dessins détaillés

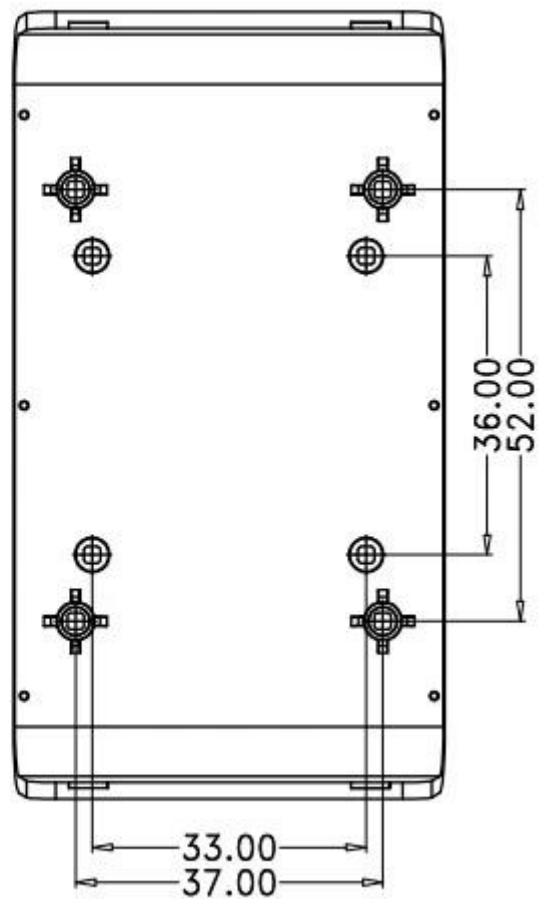
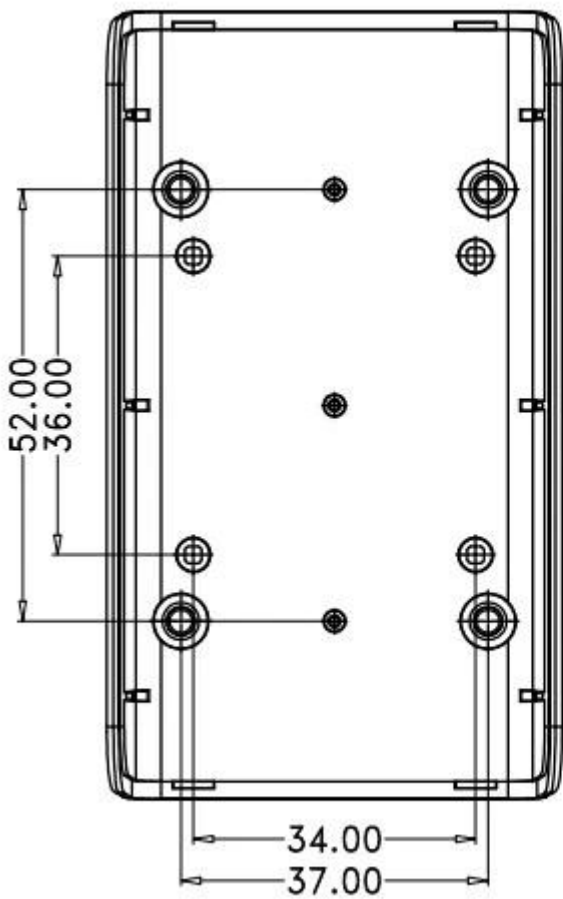
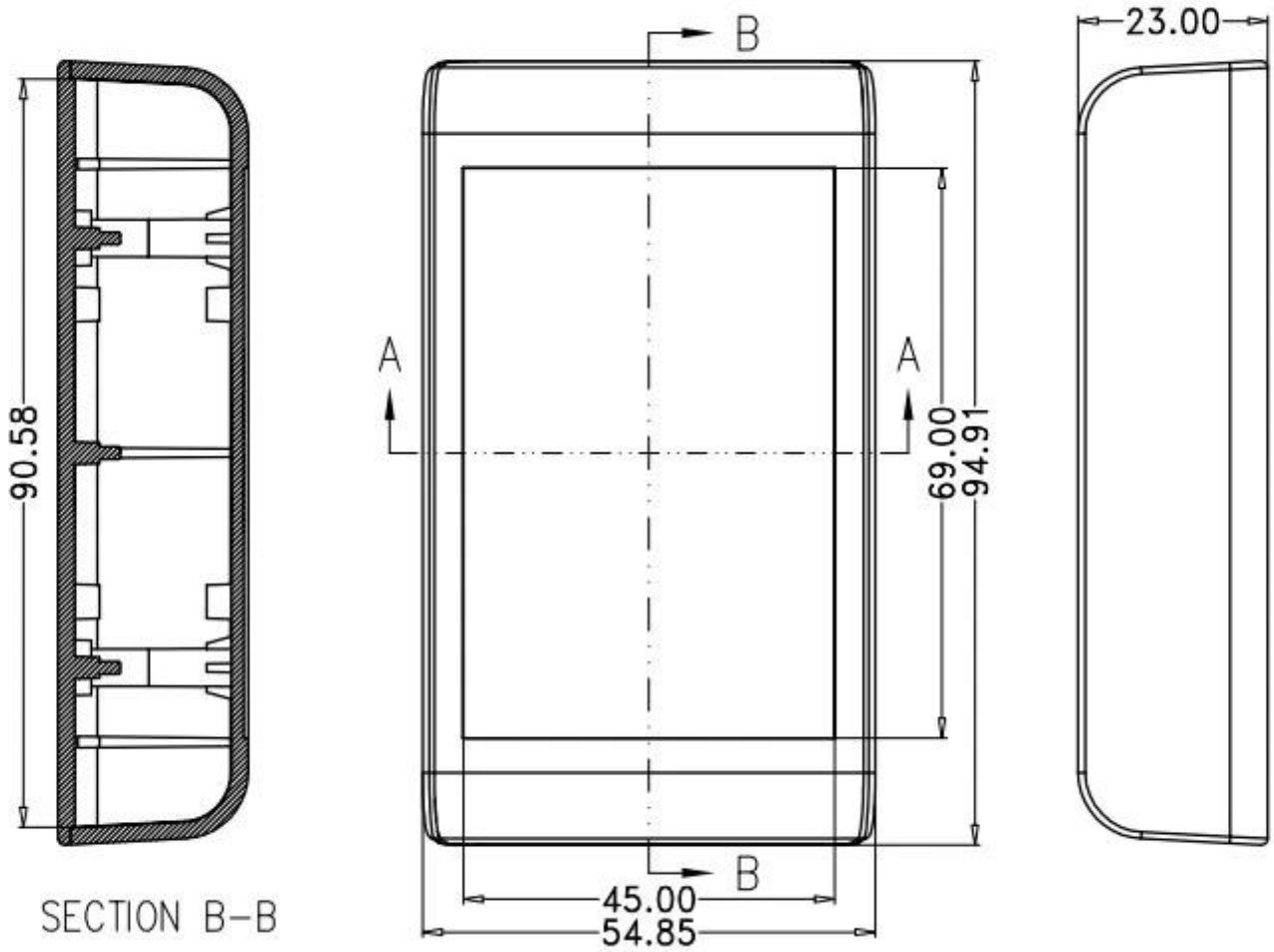

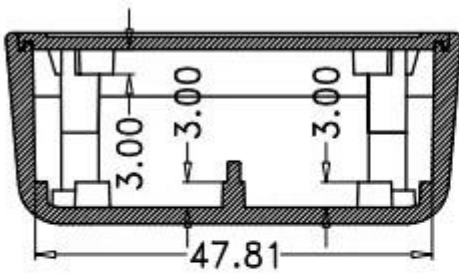

SECTION A-A

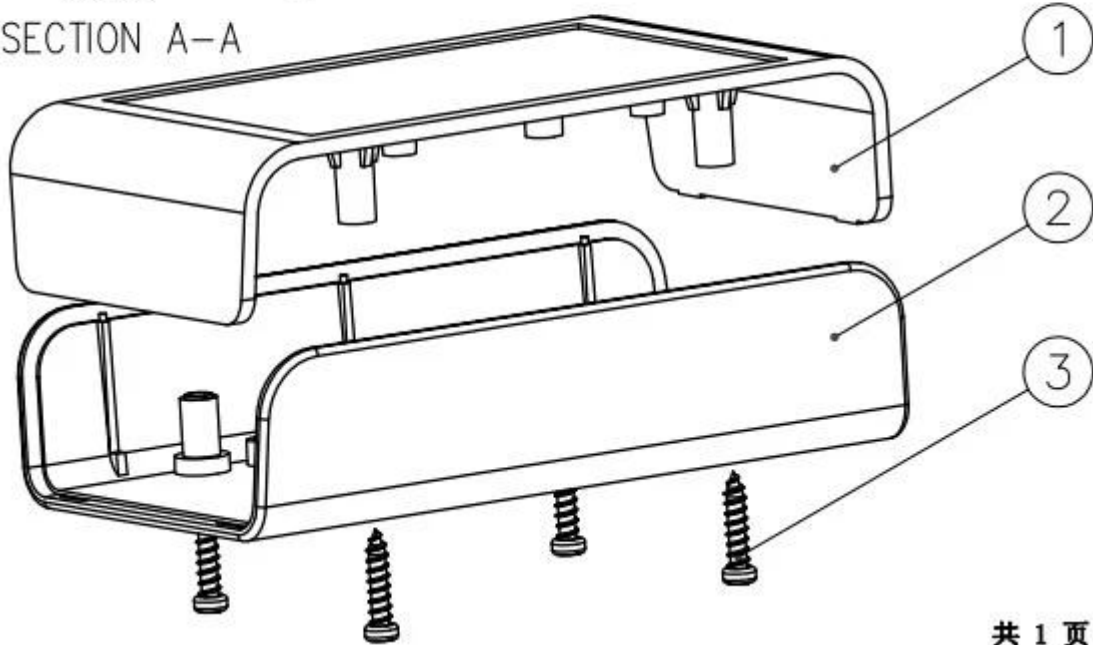

共 1 页

Autre personnalisation



SZOMAK

WE CAN DO

- Provide thousands of public enclosure**
MOQ: 1 piece
- Small order custom** MOQ: 20-30 pcs
- Design private custom enclosure (provide PCB)**
- Molding, tooling (provide sample / STEP file)**







cutout, laser engrave, screen printing, sticker, acrylic plate, pvc label, color, silica gel rings, etc.



WE CAN DO
For HOUSING some of the Processing,
Openings, Screen, Stickers, PVC LABEL



Méthodes d'emballage et d'expédition



Our packaging

Plastic foam packaging



Metal shell packaging



Plastic box packaging



Packaging & Shipping



Contactez nous



QQ

3010748891



Tel

81-755-83222882
+86 18819073301



Add

16-6Floor, 505Building ,Shangbu Industry
Area, Hangtian RD, Futian District ,Shenzhen
China



Email

smile@szomk.net



skype

szomk017