

It is widely used in electronic, instrumentation, automation, communications, power supply units, student projects, amplifiers, Medical and wellness devices, test and measurement equipment, industrial control, peripheral devices and interfaces, switch boxes.



## Avantages de la boîte de distribution électronique de boîtier en plastique abs

1. A une forte résistance à l'abrasion, aux intempéries, à la corrosion.
2. Peut être formé sur la surface d'une variété de couleurs, afin de maximiser vos besoins.
3. Avoir une forte dureté, peut être bien protégé vos appareils électroniques.

## Que pouvons-nous faire pour vous

- 1 Percer, poinçonner, etc. Bienvenue pour fournir des dessins personnalisés.
- 2 Revêtement en poudre, brosse, polonais, sérigraphie, découpage au laser, autocollant, gravure, feuille acrylique.
- 3 délai court, normalement 3-5 jours après le paiement (selon la quantité)
- 4 réponse rapide pour votre demande

## Images détaillées de la boîte de distribution électronique de boîtier en plastique abs

# SZOMK



▶ **Enclosure Manufacturer**  
[www.chinaenclosure.com](http://www.chinaenclosure.com)

# SZOMK

Customizable  
cutout, sticker  
silkscreen, color



Weight: 24g  
Model No. AK-S-01

Size: 3.15\*1.97\*0.75inch  
80\*50\*19 mm

**Détaillé dessins**

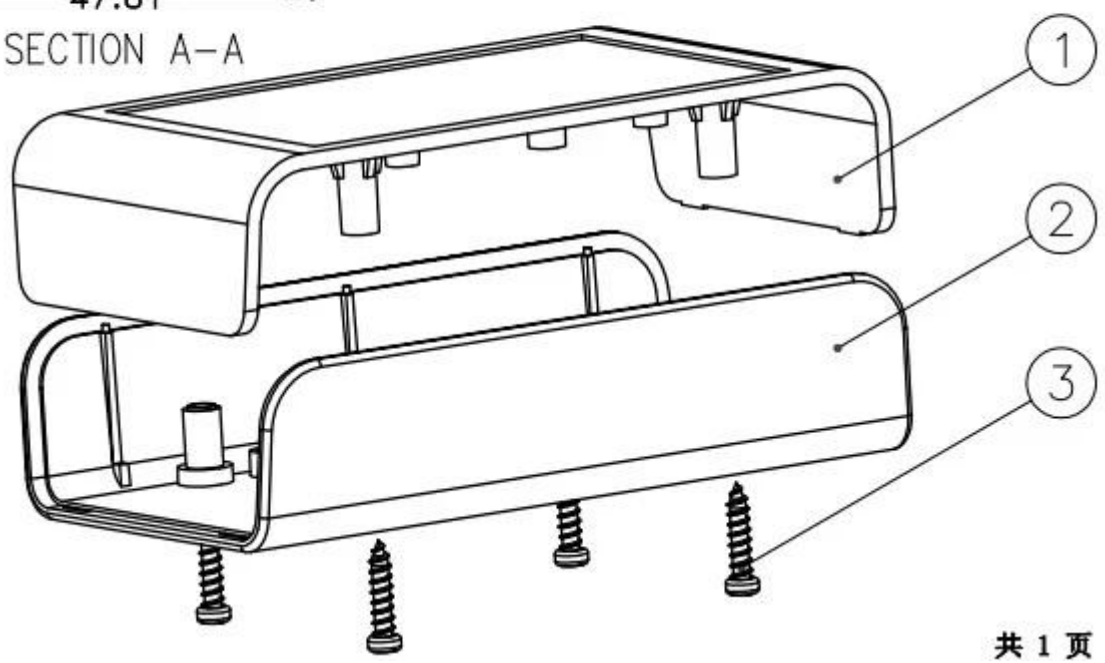
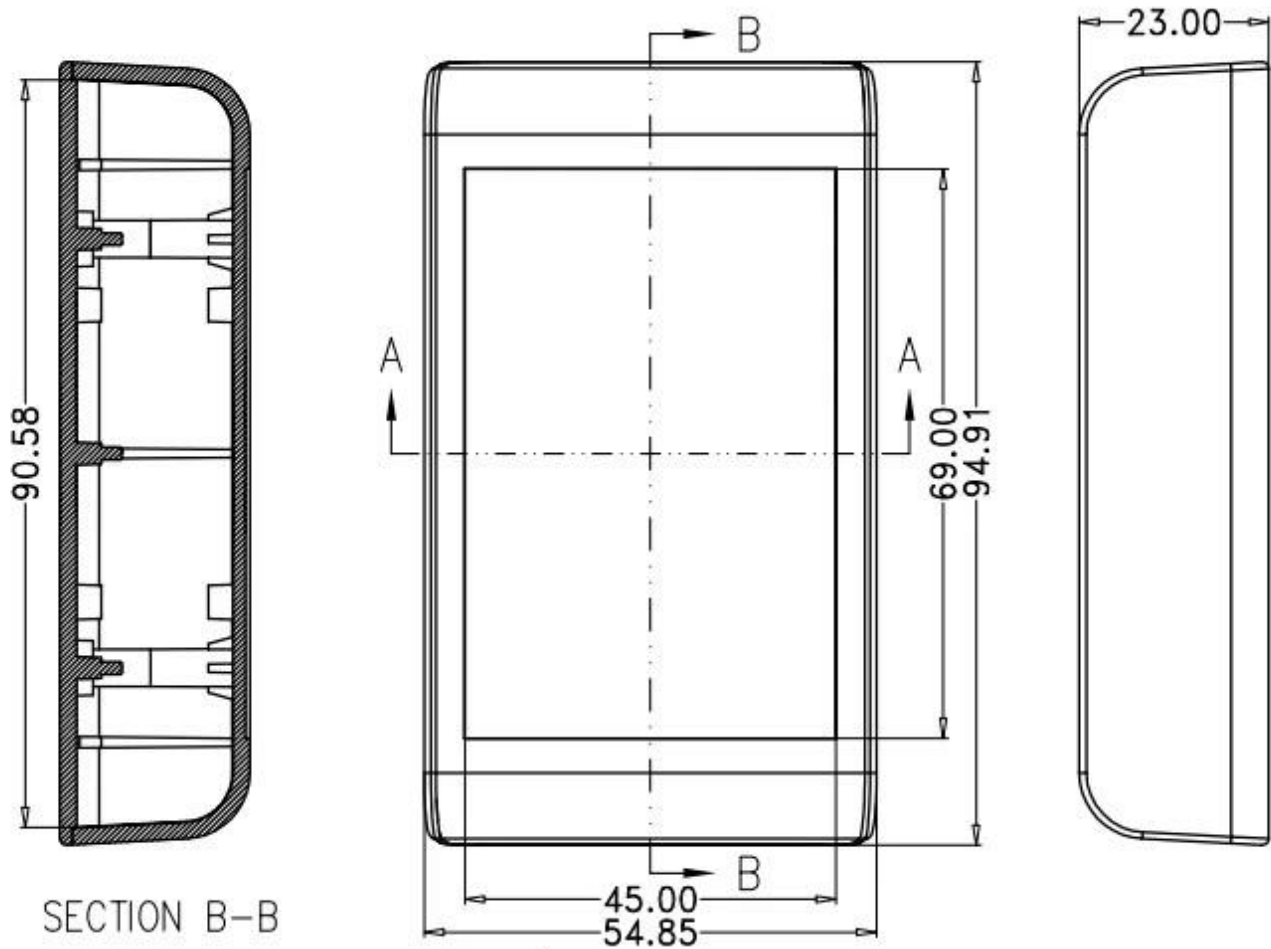

**Autre personnalisation**



**SZOMK**

## WE CAN DO

- ✓ *Provide thousands of public enclosure* MOQ: 1 piece
- ✓ *Small order custom* MOQ: 20-30 pcs
- ✓ *Design private custom enclosure (provide PCB)*
- ✓ *Molding, tooling (provide sample / STEP file)*



cutout, laser engrave, screen printing, sticker, acrylic plate, pvc label, color, silica gel rings, etc.

## WE CAN DO

For **HOUSING** some of the Processing,  
Openings, Screen, Stickers, PVC LABEL



**Méthodes d'emballage et d'expédition**



## Our packaging

Plastic foam packaging



Metal shell packaging

Plastic box packaging



# Packaging & Shipping



Contactez nous



Email

[jamila@szomk.com.cn](mailto:jamila@szomk.com.cn)



skype

szomk-004



Tel

86-755-83222882

86-18684887280



QQ

2804842423



WhatsApp

86-18684887280



Add

616Room,505 Building ,Shangbu industry,  
Hangtian road ,Futian district ,Shenzhen,  
China,518031