

## Brevi dettagli:

1 Punto d'origine: Zhejiang, Cina (continente)

2 Dettagli Packaging: lunghezza Box: 260 millimetri, Larghezza: 200mm  
Profondità: 100mm .1000pcs / box

3 Particolare di consegna: normalmente 3-5 giorni dopo il pagamento

4 prodotti di altissima qualità con la certificazione di CE, UL, ROHS

5 reponse Prompt per la vostra richiesta

## Caratterizzazione

Morsettiera PCB è caratterizzata principalmente dal monomero e il circuito di saldatura e il cablaggio semplice e affidabile collegamento a vite. Il passo è di 3,5, 3,81, 5,0, 5,08, e così via. I morsetti possono essere combinati con 3P e 2P. I prodotti senza cuciture sono inoltre disponibili. Le direzioni di cablaggio sono frontali, laterali, pendenza e altri stili differenti.

### Technical Parameters for Screw Terminal Block/Connector :

Electrical Specification	Mechanical Specification	Part & Material
Related: 300V 10A	Temp.Range: -30C-+120 C	Body: PA66,UL94V-0
Contact resistance: 20mΩ Max	Max Soldering: +250 C,5s	Screw: Steel,Zn plating
Withstanding:AC1500V/1min	Wire range: 24-18AWG	Wire Protector: Bronze,Ni plating
Torque:0.2Nm(1.8lb.in)	Strip Length: 4.5 -5mm	Terminal: Brass,Tin plating

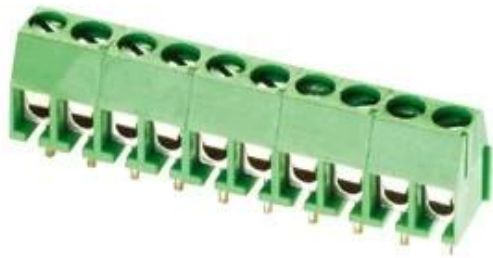

**Pitch:**

**5.0mm**

**Poles:**

**2pole 3pole to any poles**

**SZOMK**

- **Top quality products with certification of CE,UL,ROHS**
- **Short lead time, normally 3-5 days after payment**
- **Prompt reponse for your inquiry**

*Pitch=3.5/3.96*  
*Unit:mm*  
*N=Poles*

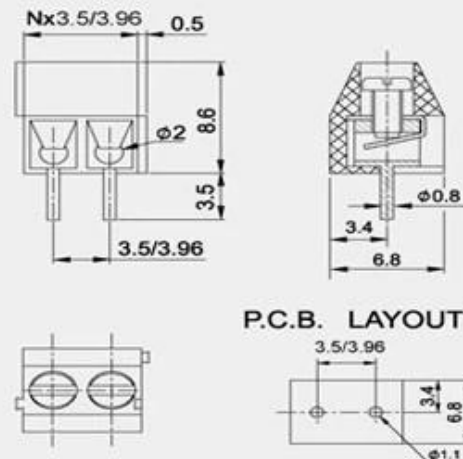

**Company Information**



**Shenzhen Futian Huaqiang Electronic World OMK Electronic Sales Departmen**

This complex, during long years of efforts with it's own experienced group and sole facilities for improvement of productions and promotion of products quality, is now one of the largest suppliers of all kinds of metallic and plastic enclosures in different fields of electronic, electrical, communication, medical, industrial and research prtojects purposes.

In today's industrial world and with the rapid development of all industries, the need of these products is sensed more than ever. Therefore by offering the best quality and service, we try to meet these needs and help you to reach your ideals.

## Exhibition



## Factory and showroom



## Certificate



## Packaging & Shipping



Shenzhen Futian Huaqiang Electronic World OMK  
Electronic Sales Department

Tel: +86-755-83222882 E-mail: [ivy@szomk.com.cn](mailto:ivy@szomk.com.cn)

