

## Product characteristics

- 1, products with packaging box, independent packing.
- 2, matching with screw convenient (client).
- 3, with slip-resistant floor mat.
- 4, shell have the relative independent panel, to facilitate the relevant client the processing openings.
- 5, all small packaging bag packing.
- 6, products material is plastic raw material

## Main usage

Desktop instrument box because and focalization geographic disparities to the scope of different names different also used for industrial main junction box, instrument box, electronic housings, etc mainly for indoor and outdoor electric, communication, fire fighting facilities, steel puddling, electronic, power, railway, construction site, stopcocks, airport, guesthouses, large factory, environmental pollution.

## Services and machining:

1. Developing molds and its machining
2. Modification of the product and its machining
3. The material and color of the products can be modified as required.
4. Additional costs are added for modification and machining depending on the mould.
5. Professional machines for punching the Enclosure

**SZOMK**



▶ **Enclosure Manufacturer**  
[www.chinaenclosure.com](http://www.chinaenclosure.com)

**SZOMK**



**SZOMK**



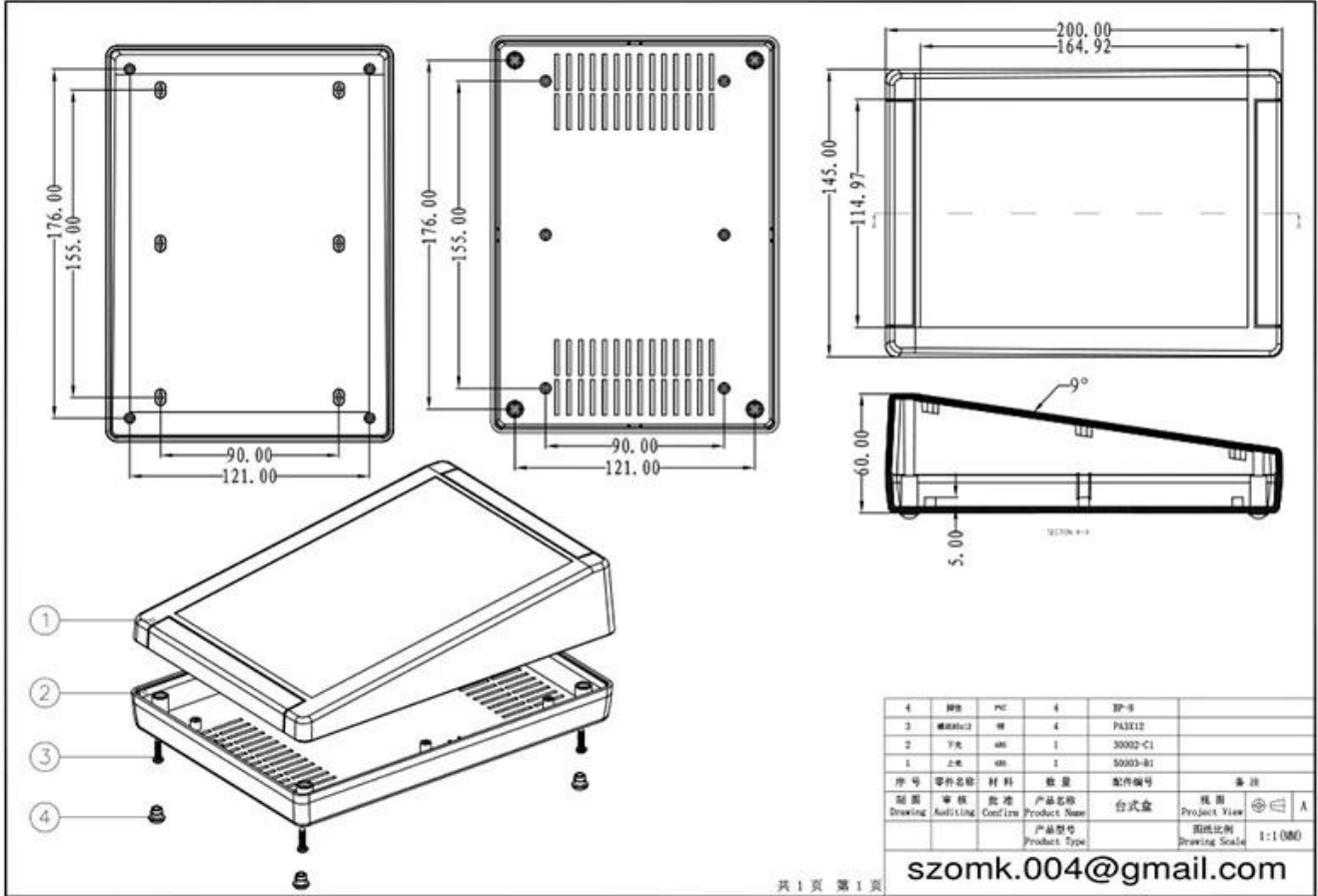

4	脚垫	PC	4	SP-8	
3	螺丝	PH	4	PH3X12	
2	下壳	ABS	1	30002-C1	
1	上壳	ABS	1	30003-B1	
序号	零件名称	材料	数量	配件编号	备注
制图	审核	批准	产品名称	台式盒	视图
Drawing	Auth/line	Confirm	Product Name		Project View
			产品类型		图纸比例
			Product Type		Drawing Scale
					1:1.000

产品型号(MODEL NO.): AK-D-14

产品尺寸 ( SIZE ): 200×145×63 mm

产品重量(WEIGHT): 257 g



18221503

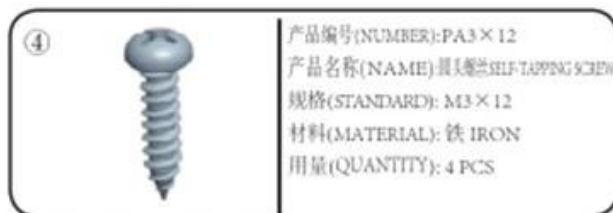
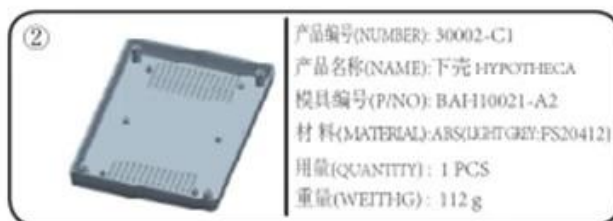
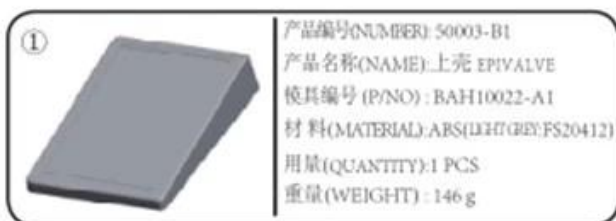
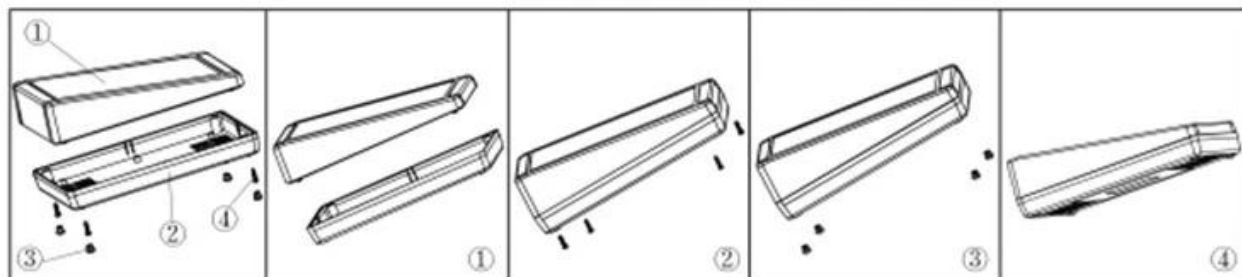



QQ

2406659781



Tel

86-755-83222882  
86-18598241813



Add

628Room,505 Building ,Shangbu industry,  
Hangtian road ,Futian district ,Shenzhen,  
China,518031



Email

emily@szomk.com.cn



skype

szomk1010