

### Преимущества жилья СЗОМК

1. Он обладает сильной коррозионной стойкостью, атмосферостойкостью, коррозионной стойкостью.
2. поверхность может быть сформирована в самых разных цветах и максимально соответствует вашим потребностям.
3. Имейте хорошую сильную жесткость, чтобы сохранить электронику.

### Что мы можем сделать для вас

- 1 Drilling, punching и так далее. Добро пожаловать в графику по запросу.
- 2 порошковая краска, щетки, полировка, шелкография, лазерная гравировка, плакаты, гравировка, панель из акриловой смолы.
- 3 короткое время доставки, обычно через 3-5 дней после оплаты (в соответствии с номером)
- 4 подсказки для вашего запроса

### **спецификация продукта**

# SZOMK



## Enclosure Manufacturer

[www.chinaenclosure.com](http://www.chinaenclosure.com)

# SZOMK

Customizable  
cutout, sticker  
silkscreen, color



Weight: 77g

Model No. AK-H-07b

Size: 4.65\*3.07\*1.30 inch

118\*78\*33 mm

**SZOMK**



**SZOMK**



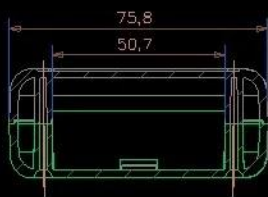
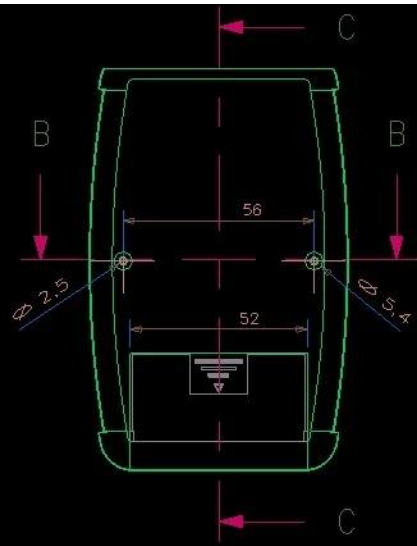

SECTION B-B

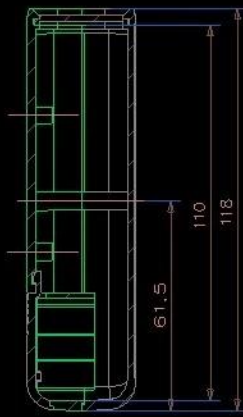

SECTION C-C

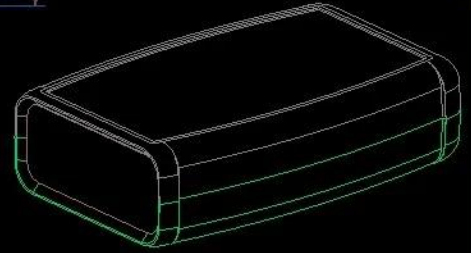



*Plate*



*Silkscreen*



*Sticker*

*We can do  
customize*

*Cutout*



*Silicone Seals*



*Color*





## Customizable

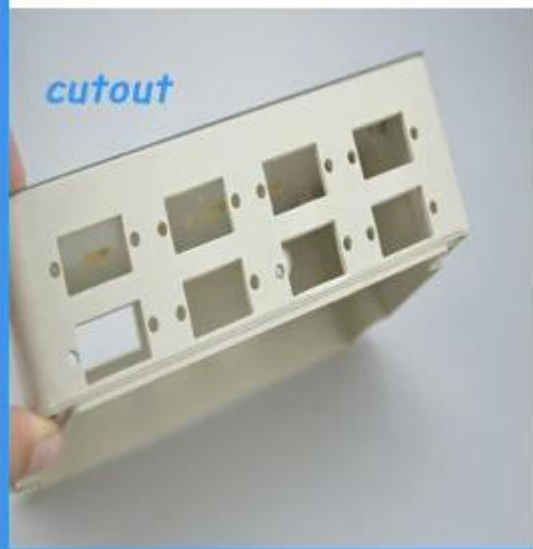

Индив

идуальные услуги

### Company Information



#### Shenzhen Futian Huaqiang Electronic World OMK Electronic Sales Departmen

This complex, during long years of efforts with it's own experienced group and sole facilities for improvement of productions and promotion of products quality, is now one of the largest suppliers of all kinds of metallic and plastic enclosures in different fields of electronic, electrical, communication, medical, industrial and research prtojects purposes.

In today's industrial world and with the rapid development of all industries, the need of these products is sensed more than ever. Therefore by offering the best quality and service, we try to meet these needs and help you to reach your ideals.

## Factory and showroom



## Exhibition





## Certificate



## Packaging & Shipping



## Контактная информация



QQ

2110283100



Tel

81-755-83222882  
+86 18819074698



Add

16-6Floor, 505Building ,Shangbu Industry  
Area, Hangtian RD, Futian District ,Shenzhen  
China



Email

teddy@szomk.net



skype

teddy@szomk.net



WeChat

teddy07277